

## Riverwalk I

Suite 520

2150 E. Lake Cook Road, Buffalo Grove, IL  
60089

HAMILTON PARTNERS  
www.hamiltonpartners.com



### DETAILS

**Square Feet:** 669 S.F.  
**Net Rent:** \$17.00/S.F.  
**OP. Expense:** \$8.35/S.F.  
**Tax:** \$2.82/S.F.  
**Gross Rent:** \$28.17/S.F.

### SUITE FEATURES

- Impressive Office Space Perfect for Tenant with Smaller Square Foot Requirement
- Large Executive Office with Beautiful Custom Built-In Cabinets & Desk
- Additional Office and/or Conference Room with Built-In Cabinetry
- One Interior Office
- Building Conference Room
- Attached 5-level Structured Parking Deck
- Sushi Deli & Cafeteria
- On-Site Management
- Work-Out Club
- Convenient Access to Tollway & Transportation Systems

### FIFTH FLOOR PLAN

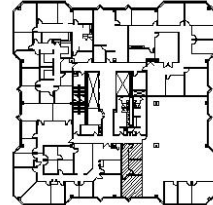

### SPACE PLAN

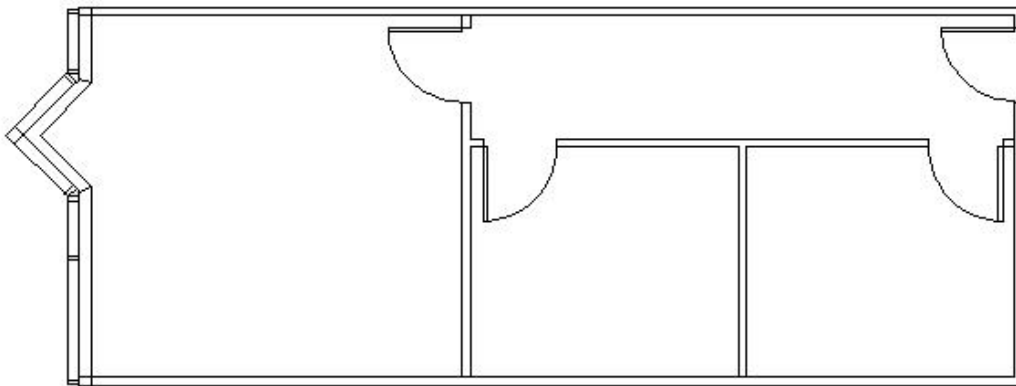

### HAMILTON PARTNERS - Sponsoring Broker

#### Brian Lunt

[blunt@hpre.com](mailto:blunt@hpre.com)

P 847-459-2249

F 847-459-8918

#### Mike Rolfs

[mrolfs@hpre.com](mailto:mrolfs@hpre.com)

P 847-459-5561

F 847-459-8918