

1101 Perimeter Drive
Suite 485
Schaumburg, IL 60173



SUITE FEATURES

- Lobby Exposure
- WIFI Lounge
- Building Conference Room
- Adjacent to Woodfield Mall
- Energy Star

FOURTH FLOOR PLAN

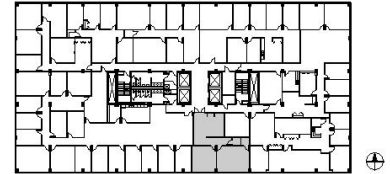

DETAILS

Square Feet: 1,186 S.F.
Net Rent: \$10.50/S.F.
OP. Expense: \$7.69/S.F.
Tax: \$3.43/S.F.
Gross Rent: \$21.62/S.F.
Divisible: YES

Â

SPACE PLAN

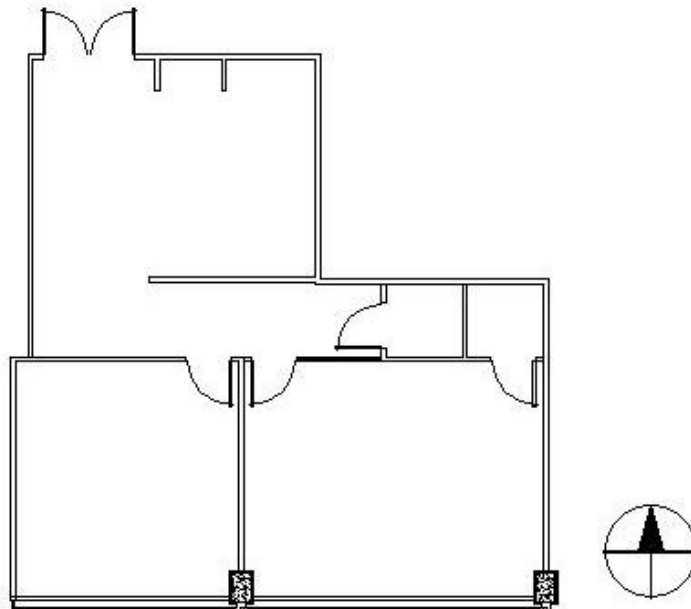

HAMILTON PARTNERS - Sponsoring Broker

Patrick McKillen

✉ pmckillen@hpre.com

P 630-250-4907

F 630-251-8521

Paul O'Connor

✉ poconnor@hamiltonpartners.com

C 6309210142

Scott Schroeder

✉ sschroeder@hpre.com

P 630-250-4898

F 630-250-8521