

Riverwalk I

Suite 520

2150 E. Lake Cook Road, Buffalo Grove, IL
60089

HAMILTON PARTNERS
www.hamiltonpartners.com



SUITE FEATURES

- Building Conference Room
- Attached 5-Level Parking Deck
- Food Service
- On-Site Management
- Fitness Center
- Convenient Access To Tollway

FIFTH FLOOR PLAN

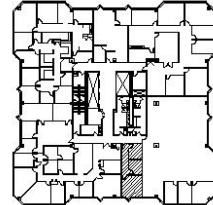

DETAILS

Square Feet: 699 S.F.
Net Rent: \$17.00/S.F.
OP. Expense: \$8.35/S.F.
Tax: \$2.82/S.F.
Gross Rent: \$28.17/S.F.

SPACE PLAN

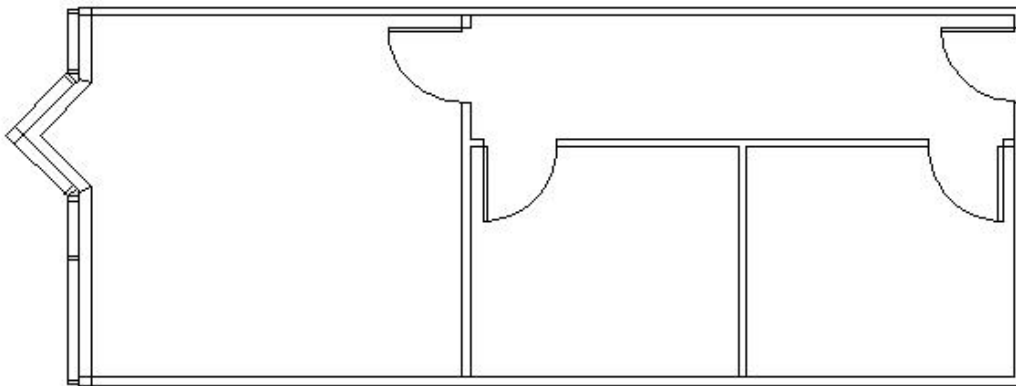

HAMILTON PARTNERS - Sponsoring Broker

Brian Lunt

blunt@hpre.com

P 847-459-2249

F 847-459-8918

Mike Rolfs

mrolfs@hpre.com

P 847-459-5561

F 847-459-8918