

AVAILABLE FOR LEASE

210,641 SF



1321 W. Thorndale Ave
ITASCA, IL 60143

Contact us:

Industrial Division

630-250-9700

industrial@hpre.com

300 Park Boulevard

Suite 201

Itasca, IL 60143

hpre.com

About This Property

- Available: 210,641 SF
- Building Size: 310,916 SF
- Office SF: 4,120 SF
- Clear Height: 30'
- Exterior Docks: 35
- Loading: 1 Drive In Doors
- Sprinklers: ESFR
- Excellent location, centrally located within the metropolitan Chicago area
- 1/2 mile to I-390/I-355
- 1.7 miles to the Itasca Metra Train Station
- 10 miles to O'Hare International Airport South cargo center

HAMILTON
PARTNERS

Site Plan

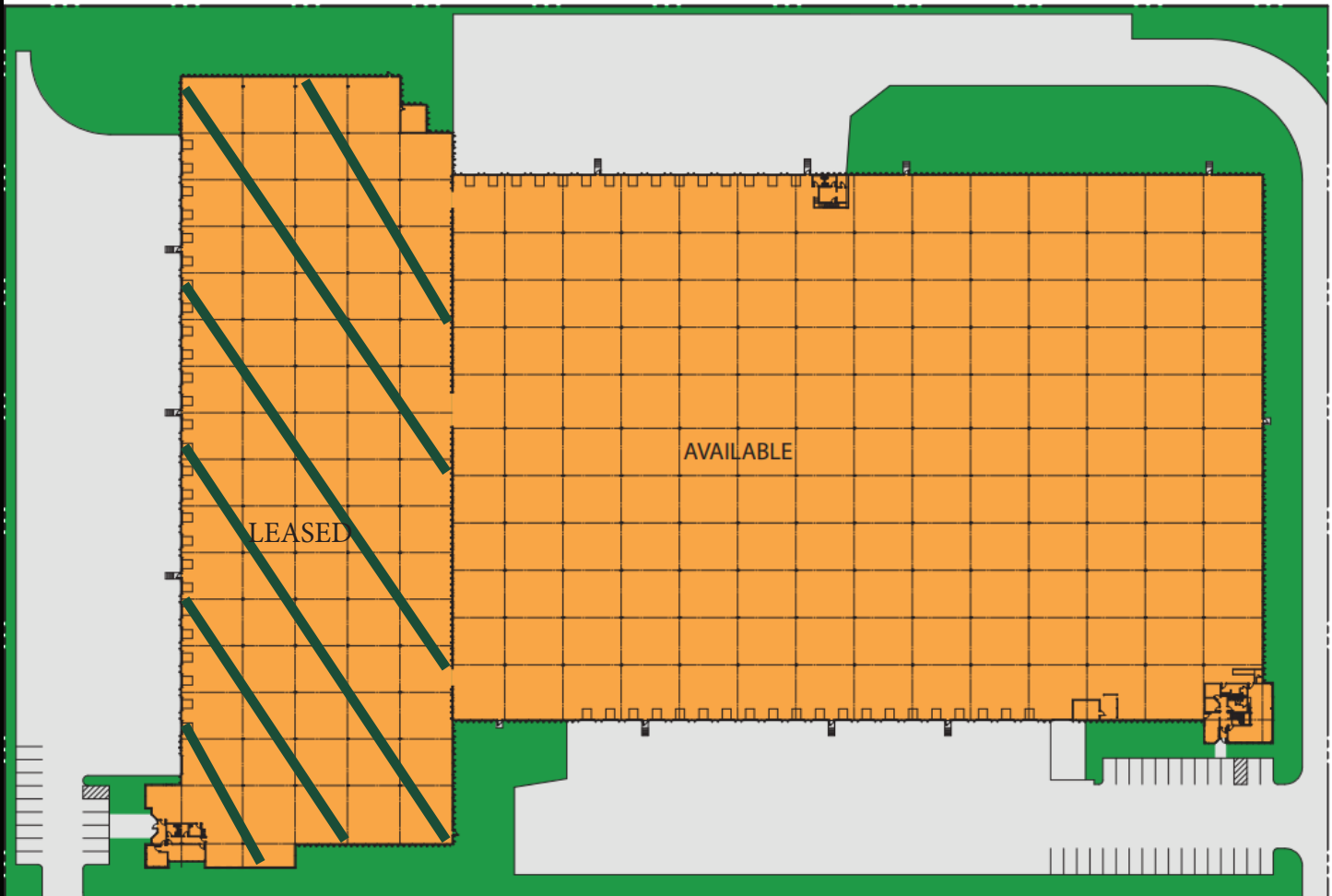

Hamilton Partners
Industrial Division
630-250-9700
industrial@hpre.com

HAMILTON
PARTNERS

Building Plan

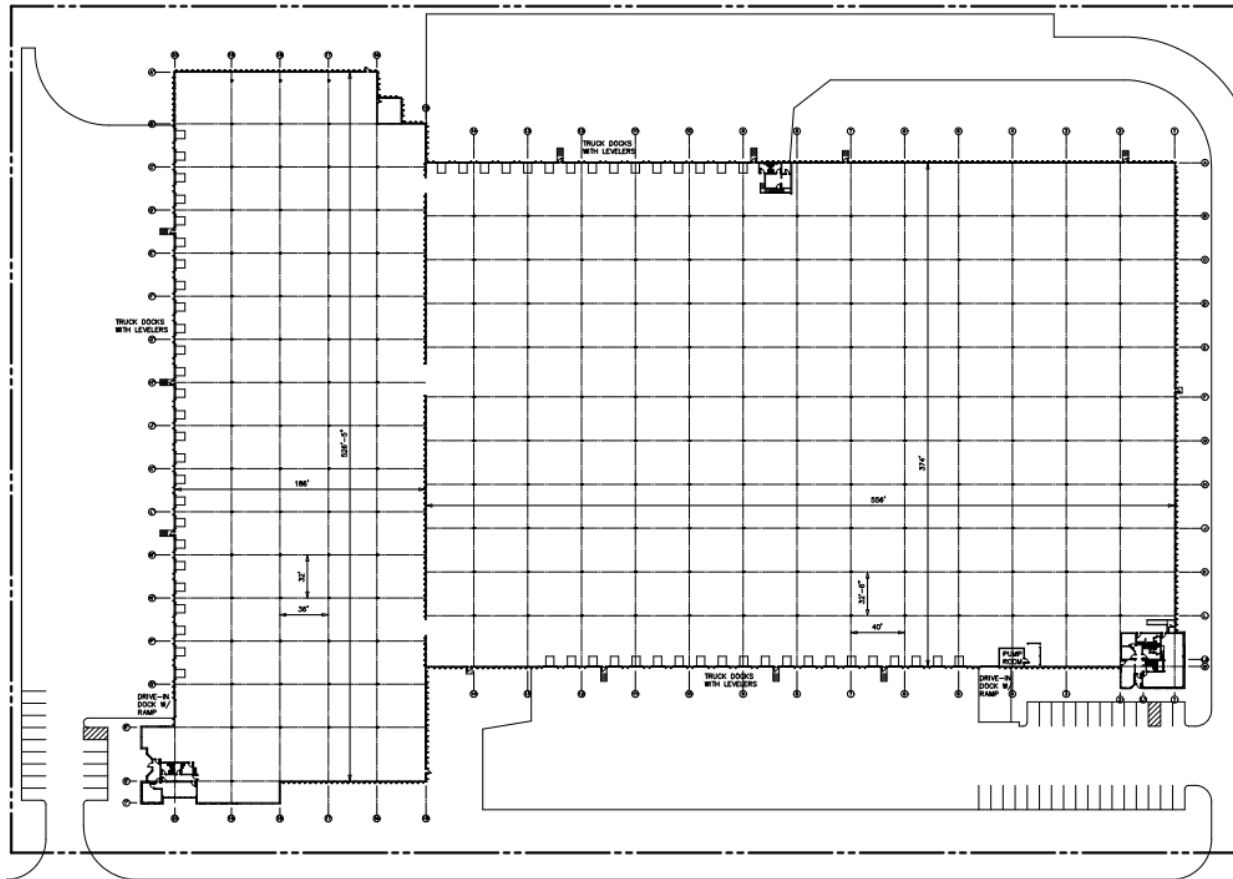

Hamiton Partners
Industrial Division
630-250-9700
industrial@hpre.com

HAMILTON
PARTNERS

Office Plan

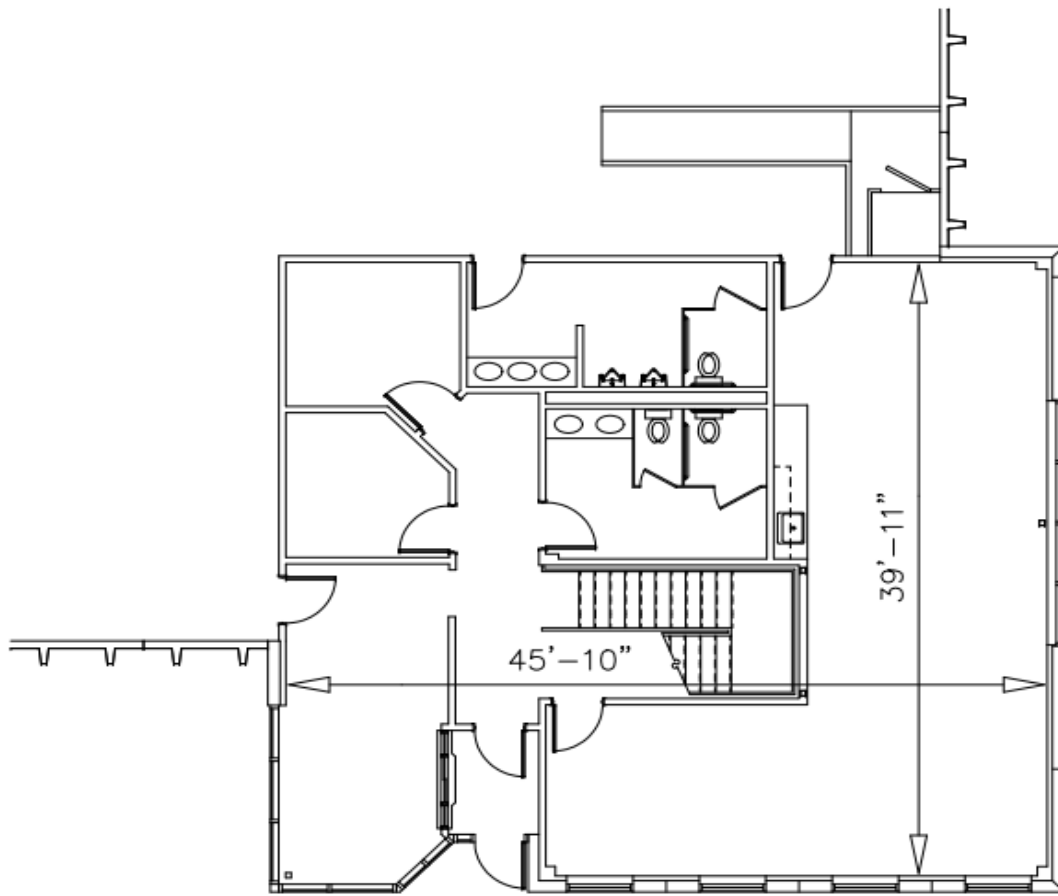

S.E. OFFICE PLAN - 1st FLOOR

1820 SF



Hamilton Partners
Industrial Division
630-250-9700
industrial@hpre.com

HAMILTON
PARTNERS

Office Plan

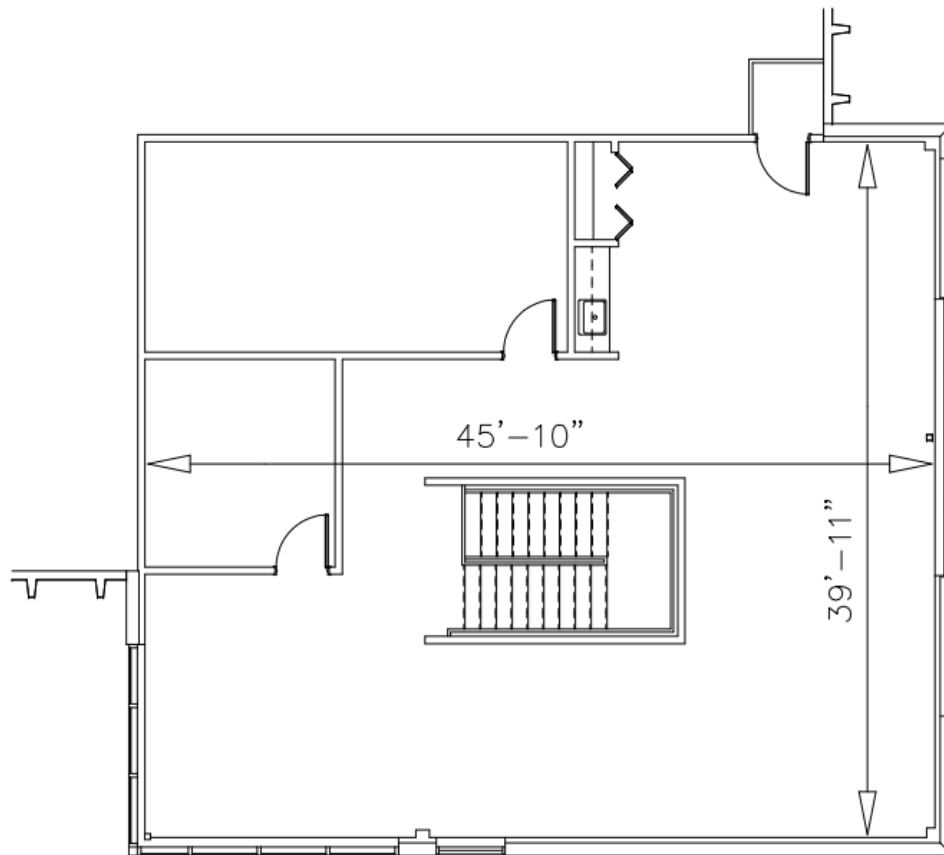

S.E. OFFICE PLAN - 2nd FLOOR

1760 SF



Hamilton Partners
Industrial Division
630-250-9700
industrial@hpre.com

HAMILTON
PARTNERS

Office Plan

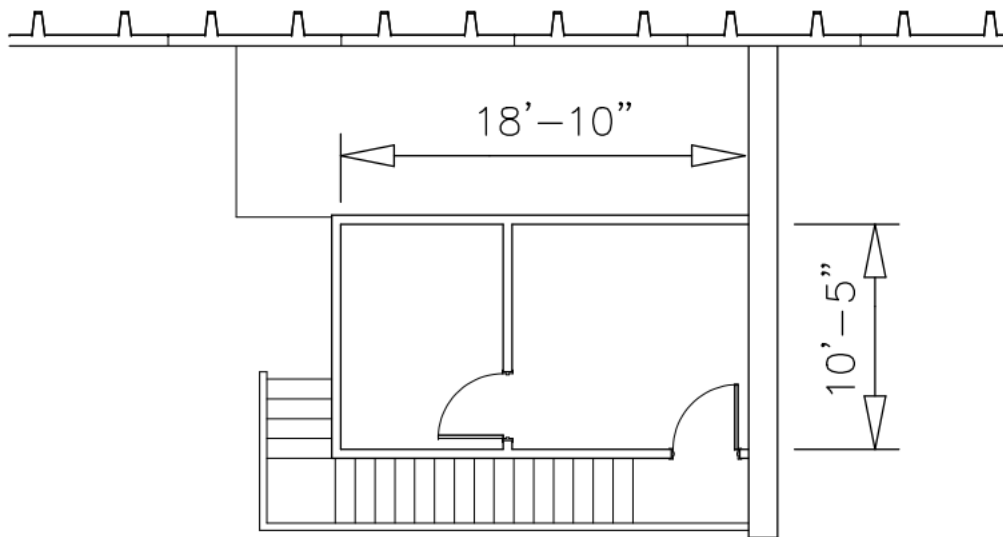

N. OFFICE PLAN - 2nd FLOOR

200 SF



Hamilton Partners
Industrial Division
630-250-9700
industrial@hpre.com

HAMILTON
PARTNERS

Office Plan

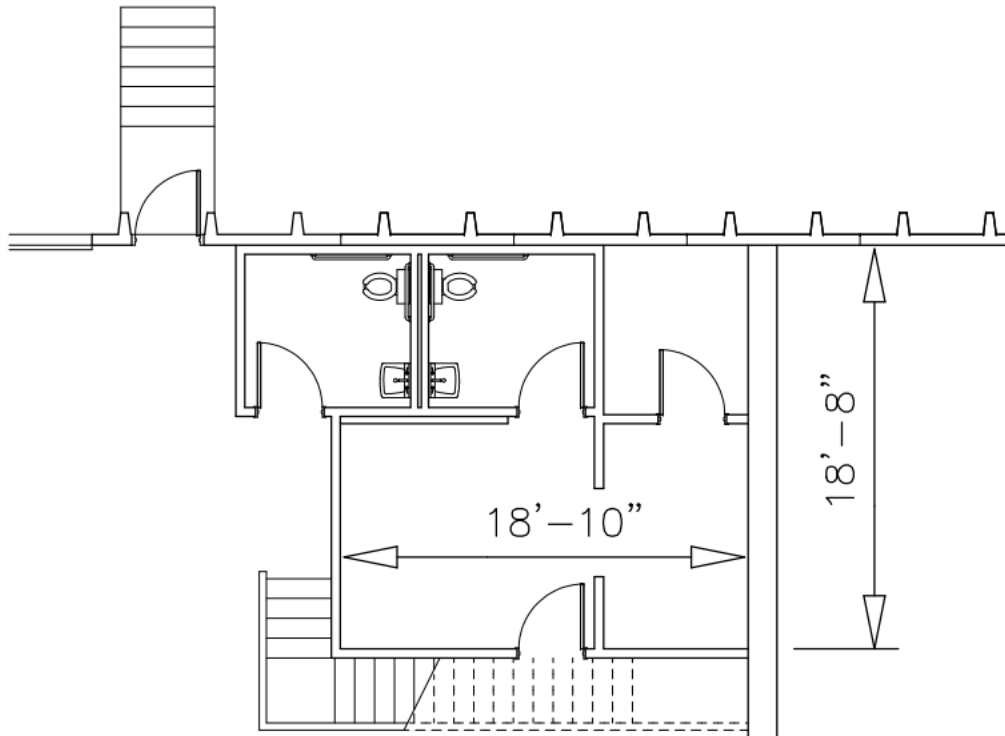

N. OFFICE PLAN - 1st FLOOR

400 SF



Hamilton Partners
Industrial Division
630-250-9700
industrial@hpre.com

HAMILTON
PARTNERS

Map

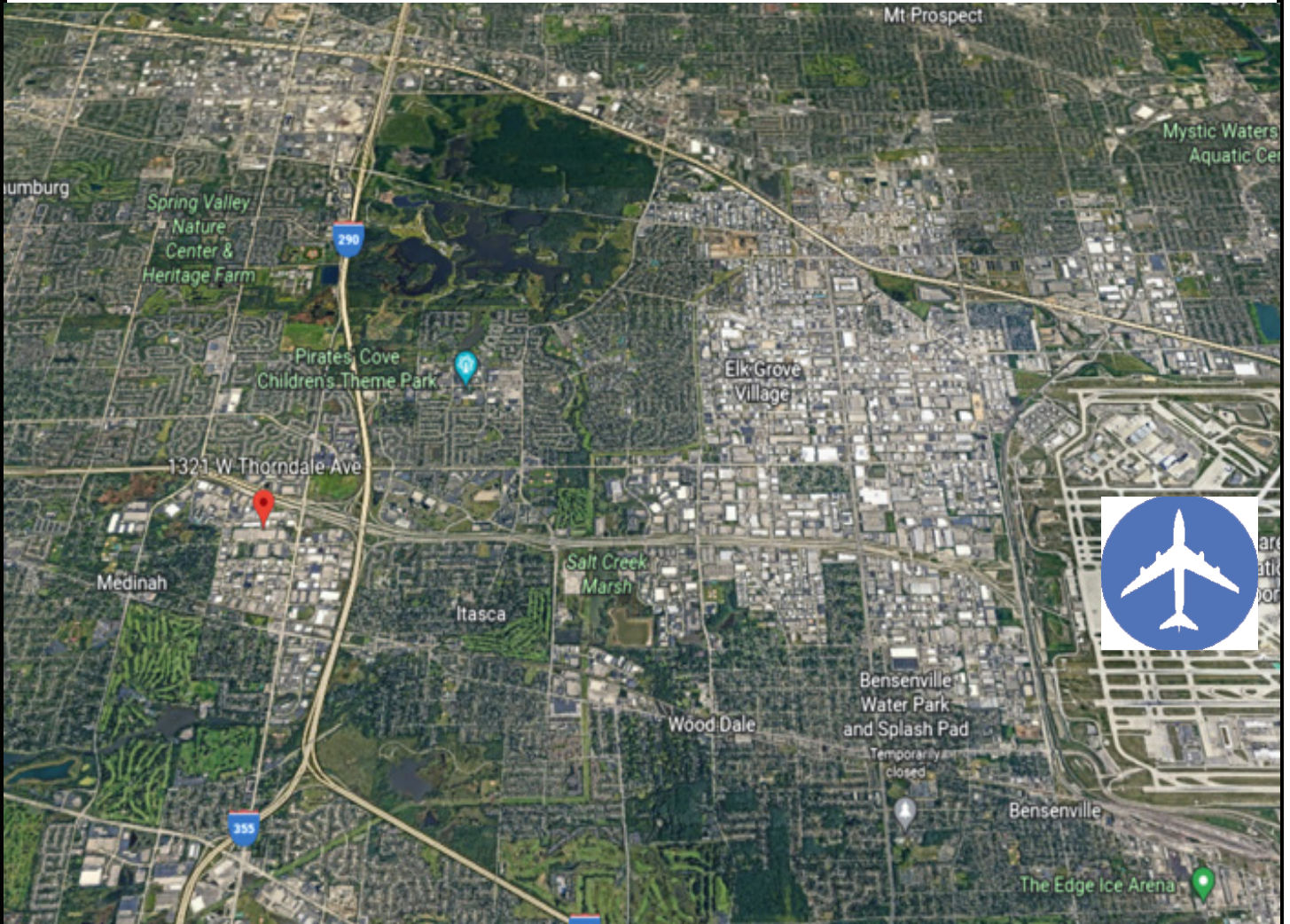

Hamilton Partners
Industrial Division
630-250-9700
industrial@hpre.com

HAMILTON
PARTNERS

Photos

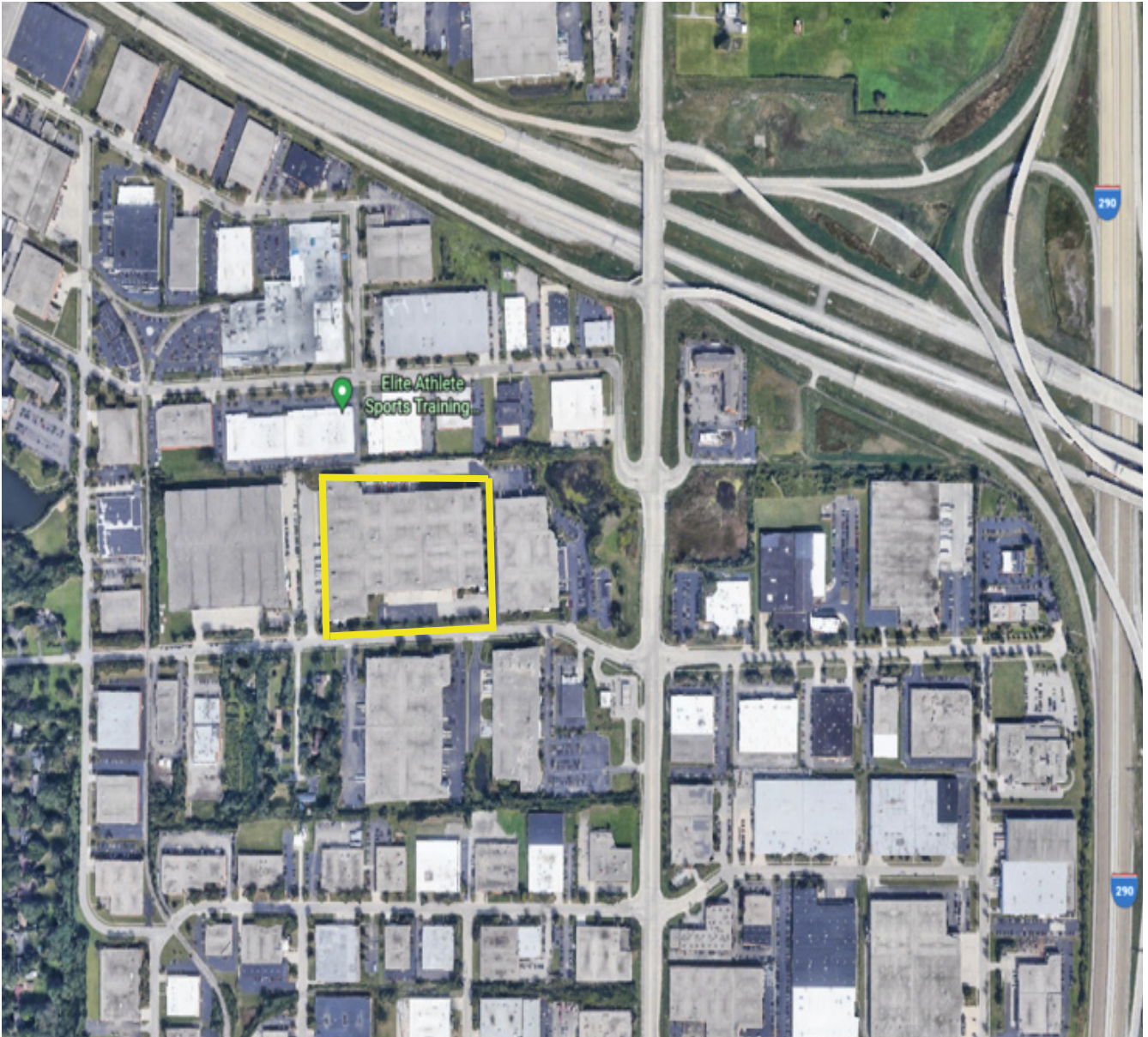

Hamilton Partners
Industrial Division
630-250-9700
industrial@hpre.com

HAMILTON
PARTNERS

Photos

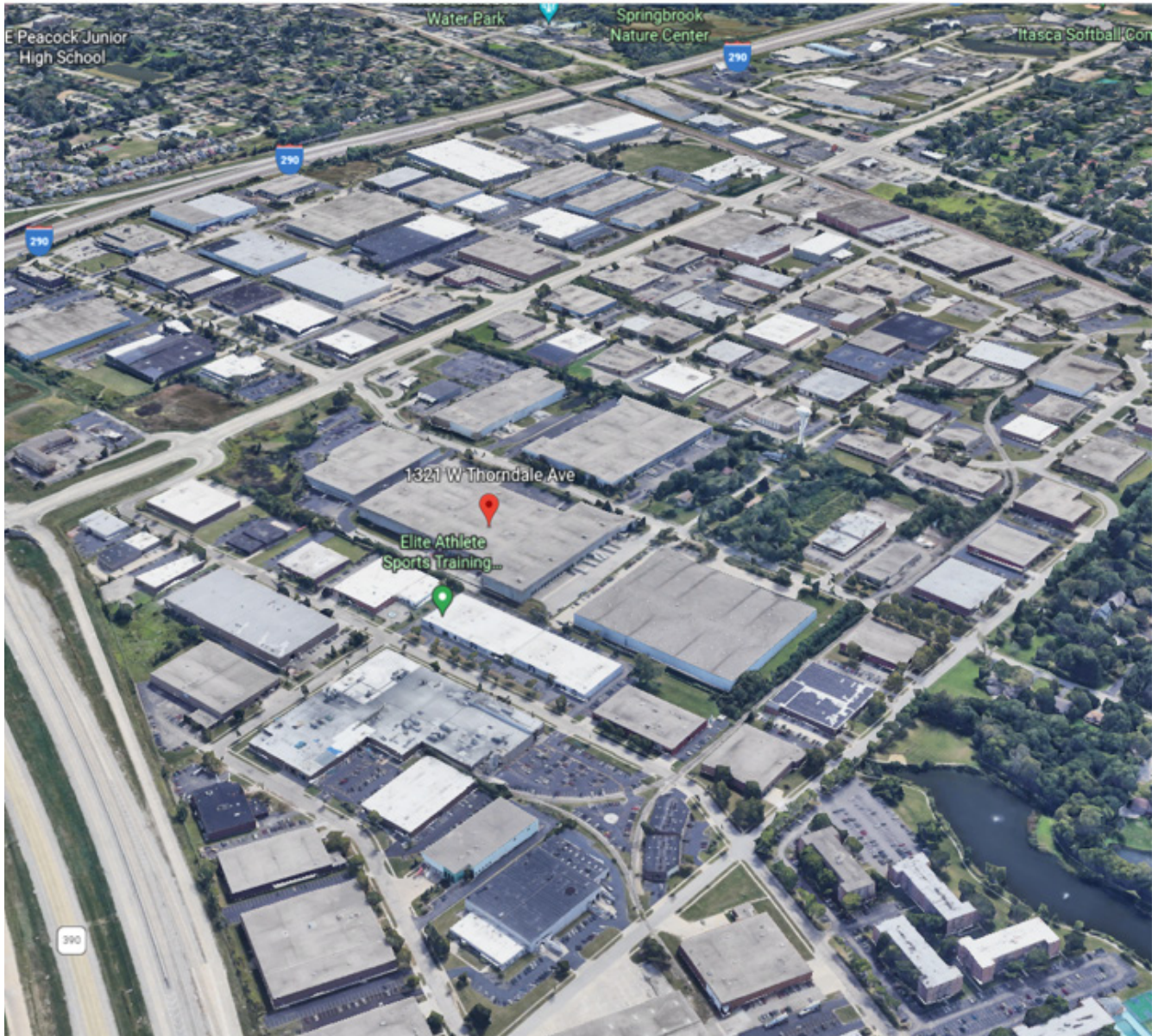

Hamilton Partners
Industrial Division
630-250-9700
industrial@hpre.com

HAMILTON
PARTNERS